

# Engineering Change Notice

Part No. <u>99</u>	ECN No. <u>20-044</u>
Part Name <u>'AA' BATTERY CLIP</u>	Date <u>5.12.20</u>
Rev. <u>E</u>	ECR No. <u>—</u>

Description of Change:  Drawing Attached  
CRITICAL DIMENSION : DISTANCE BETWEEN MTG. HOLES .219 [5.55]  
ADDED TO MANUFACTURING DRAWING.

Solution:  Tooling Change Required  
REVISE C+M

Disposition of Parts:  
U.A.I.

Signed RH Date 5.12.20

Required Distribution:

<input checked="" type="checkbox"/> Engineering	<input checked="" type="checkbox"/> Quality Control	<input type="checkbox"/> Purchasing	<input checked="" type="checkbox"/> Manufacturing/Supplier
---	---	-------------------------------------	--

Chief Engineer: \_\_\_\_\_ Remarks: \_\_\_\_\_

Signed RH Date 5.12.20

Document Control: \_\_\_\_\_ Rev. F

Change Incorporated Signed NATASHA T. Date 5.12.20

THIS DOCUMENT IS THE PROPERTY OF KEYSTONE ELECTRONICS CORP. AND SHALL NOT BE REPRODUCED, DISTRIBUTED OR USED AS A BASIS FOR MANUFACTURE WITHOUT PRIOR WRITTEN PERMISSION FROM KEYSTONE ELECTRONICS CORP.

ACTUAL SIZE



REQUIRED SPACING FOR 'AA' CLIP

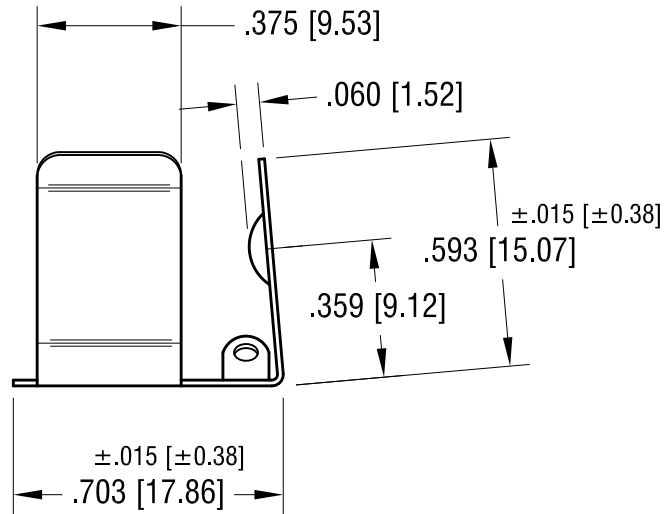
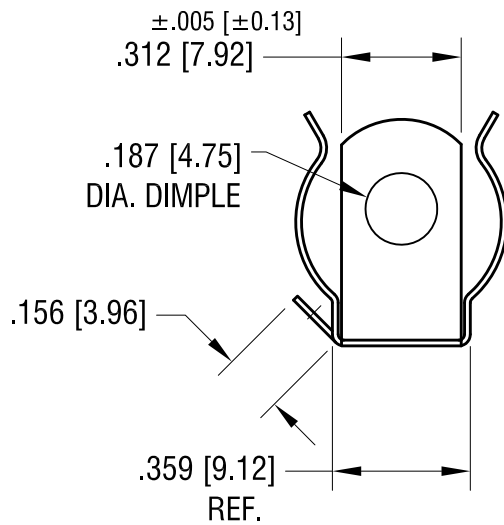
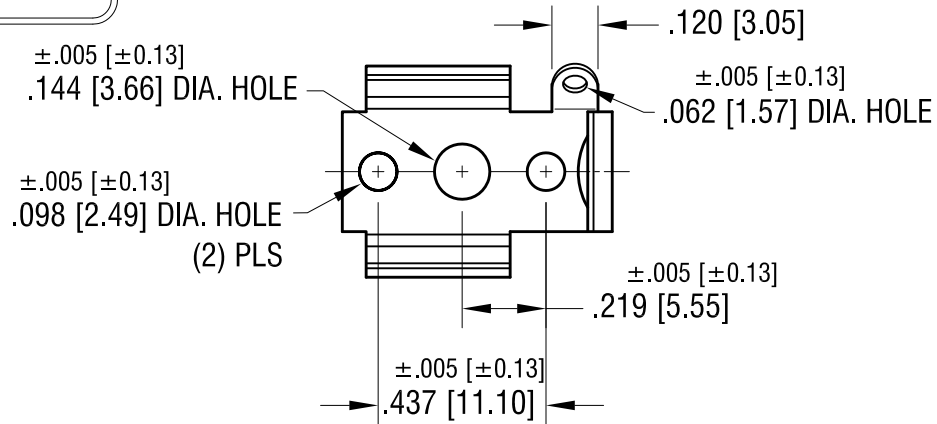
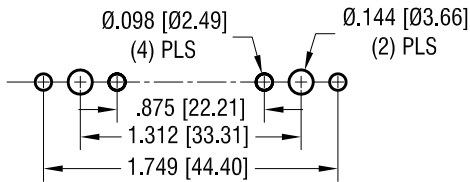

NOTE:

- 1. HEAT TREAT TO SPRING TEMPER.

5.12.20	CHANGE AS PER ECN 20-044	F
10.06.16	CHANGE AS PER ECR 16-058	E
11.4.02	CHANGE AS PER ECN 02-073	D
5.17.00	CHANGE AS PER ECN 00-033	C
DATE	DESCRIPTION	REV.

<b>KEYSTONE ELECTRONICS CORP.</b>			
www.keyelco.com • NEW HYDE PARK, NY 11040 • Tel (516) 328-7500			
PART NAME		'AA' BATTERY CLIP	
MATERIAL		.015 [0.38] TH'K ANNEALED SPRING STEEL	
FINISH		DRN BY	DATE
NICKEL PLATE		BOONE	11.05.81
		APP'D	SCALE
		RH	2X
TOLERANCES	INCH [MM]	CODE	DWG NO.
DECIMAL	± .010 [± 0.25]	C	<b>99</b>
ANGULAR	± 2°		
UNLESS OTHERWISE SPECIFIED			